

IntelliShift VG-6 Installation Guide with Temperature

Installation of your new device should be performed by a 12V certified technician or mechanic familiar with automotive 12V systems.



Temperature Sensor

- Yellow (Data, connect to Pin 6)
- Black (Ground, connect to Pin 1)
- Red (Do not use, tape off)
- For successful installation, you will need to provide a roll of 22-gauge wire (Nothing bigger than that or else you'll run into Resistance issues and the Temperature probe will not read correctly, reason being is the probe translates the Temp reading via OHMs), Wire loom, heat shrink butt connectors, clear silicone, mounting zip ties and hardware if need be.

- To be installed where the factory Temperature Probe is on the Refer unit. That is the only spot where the probe should be to ensure proper temp reading for the customer.
- For Trucks, the wiring for the probe and how you extend it should go from the probe inside the fridge unit, through a passage where the refer wiring comes out (in extreme cases where it's difficult to run the wires through, drill a hole as close to the unit as possible) from the box to the engine outside on top of the unit. Then to follow down along the side of the unit through underneath the cab and then to wherever inside our device is mounted.
- For Vans, Mount probe where the factory or as close to factory as possible, then follow the wiring to where it enters the main cab and to our device.
- If you are wiring multiple temp probes, please wire them together in series, one after the other in a single line going toward the device.

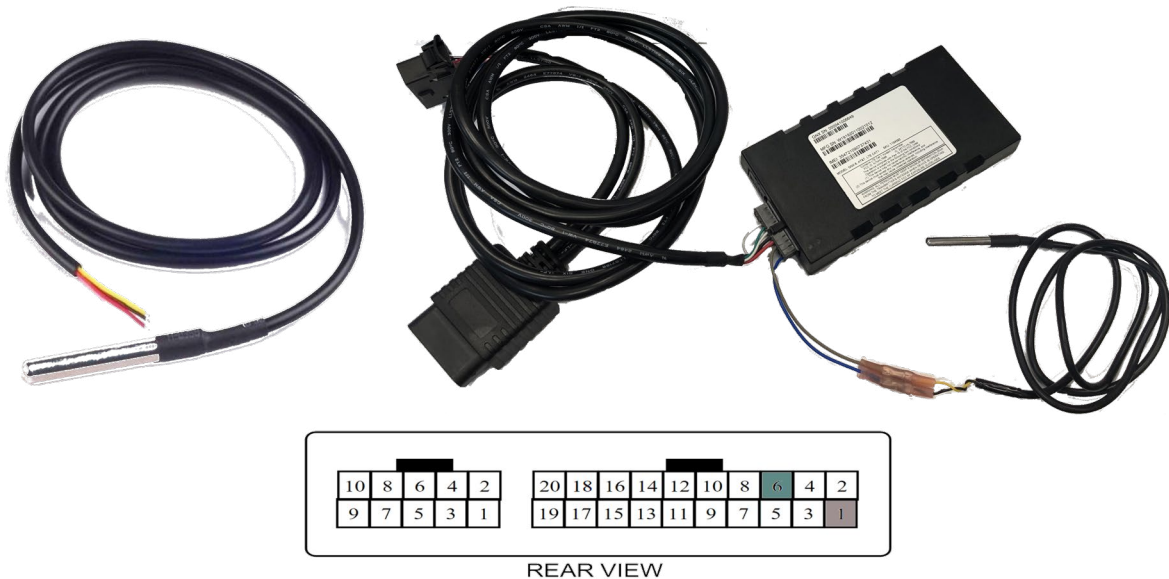

Mounting Guidelines

- The device should be installed under the dashboard with a clear line of sight to the sky, and as close to the windshield as possible. Place the device with barcode decal "THIS SIDE TOWARDS SKY" facing up. (Reference diagram A)
- DO NOT install the unit underneath metal as the signal will not penetrate and reach the satellite.
- During the initial installation, the vehicle should ideally be outside to ensure the best GPS signal. The devices may not report a location to the satellite if it is inside a garage or other structure.
- Secure the device with Velcro, and/or zip ties to ensure it is solidly mounted to the vehicle.

Installation Guidelines

- After securing the harness within the vehicle it is now time to power up the device.
- With the Ignition Off, Plug in the device to the Molex Connector.
- During the boot up process the device will show a Solid Green light for 30 Seconds
 - This represents the device powering up
- After the device has powered up the Green LED will start to Flash at the following Rates
 - 25 times on-off every 10 seconds when the ignition is on
 - Eight times on-off every 10 seconds when the ignition is off
- During the installation if you see a Red LED flashing please be sure to review the section on Troubleshooting
- Before finalizing installation, contact our Support Department at **(631) 670-1623** to verify the device is properly reporting to **IntelliShift**.

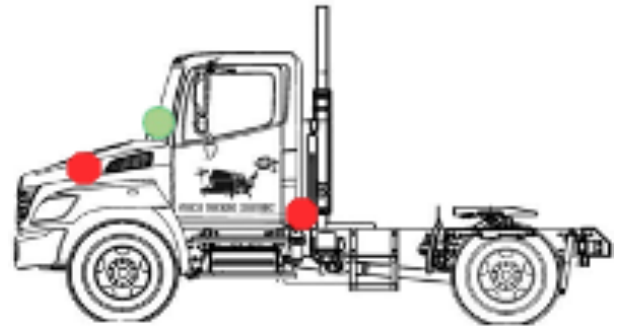
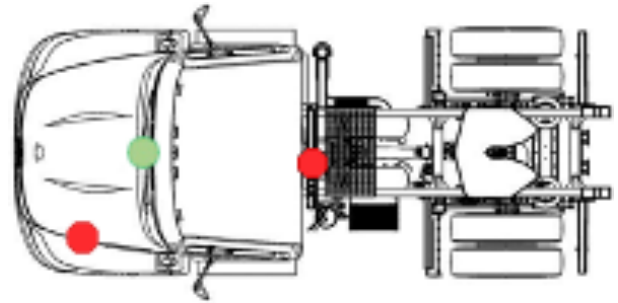

1-X Error Codes: IntelliShift-Specific Errors

- **1-1:** The device has an expired license key due to a failure to resync with the IntelliShift configuration server. Contact IntelliShift with the serial number of the device.
- **1-2:** Low supply voltage. This could be caused by a true low voltage condition (<8V) or a high impedance supply that dips in voltage when the current draw spikes due to modem transmit.
- **1-3:** Allocated data usage exhausted. Contact IntelliShift Technical Support for further instructions.

2-X Error Codes: Modem Related Error Codes

- **2-1:** Modem module fault. Contact IntelliShift for failure analysis and repair.
- **2-2:** No SIM inserted. Make sure the SIM drawer contains a SIM and that it is correctly seated in the socket. If it is, then contact IntelliShift for failure analysis and repair.

Troubleshooting:

The Green and Red LEDs are intended to aid in troubleshooting installations. Below is a summary of their behavior.

Green LED

- See Installation Guidelines.

Red LED

- The red LED flashes two-digit codes. The first digit indicates which general area is having a problem (hardware, modem, GPS, end-end service). The second digit gives specific error information. Since there can be more than one error condition, the device rotates through the error codes (e.g. if the GPS is tracking no satellites and the modem is not registered).

- **2-3:** No signal. Check that the cellular antenna is correctly attached. Try to substitute a known-good cellular antenna to see if the antenna may be broken. If this fixes the problem, then reinstall a new antenna. If not, then RMA the unit to IntelliShift for failure analysis and repair.
- **2-4:** Network not found. Contact IntelliShift.
- **2-5:** Last data session failed. This means that an attempt to establish a data session failed. This failure will occasionally happen in a working unit, but if the problem is persistent Contact IntelliShift.
- **2-6:** Network is not available.

3-X Error Codes: GPS Related Error Codes

- **3-1:** GPS module fault: Contact IntelliShift for failure analysis.
- **3-2:** GPS antenna fault: try replacing the GPS antenna with a known good antenna. If the condition is not corrected after 2 minutes, contact IntelliShift for failure analysis.
- **3-3:** GPS not tracking any satellites. Check that the GPS antenna has a clear, unobstructed view of the sky and has been operating for at least five minutes. Check that the GPS antenna is facing the correct way up. If the condition persists contact IntelliShift for failure analysis.
- **3-4:** GPS no fix (less than three satellites). If the antenna only has a partial view of the sky due to the position of the vehicle (e.g. under a cover, close proximity to a building, etc.) then try to move the vehicle to ensure that it will be able to make fixes when standing in the open. If the vehicle has a full view of the sky and the error condition persists then try to reposition the GPS antenna to reduce any obstructions from its view of the sky.
- **3-5:** GPS has no time. The GPS receiver sets

its internal clock from the satellite signals. If the GPS receiver has no time, then it has never seen a single satellite since the device was last power cycled.

4-X Error Codes: End-to-End Application Error Codes

- **4-2:** Data transfer failed. If the condition persists then contact IntelliShift Technical Support.

Temp Sensor Troubleshooting

- If you're installing is done and we don't have a temperature sensor reading, please make sure all your connections are correct. If we are getting a temperature reading and it's different than what the Temp Monitor inside the truck is saying, please confirm that you mounted the Temp probe right next to the factory probe. Please make sure you also do not use wire bigger than 22 gauge for the install as anything larger than that will throw the temp readings off.
- We pride ourselves on making our installations look as factory as possible. Please use Wire Loom to conceal the wires you run throughout the customer's vehicle if in plain sight and when it's exposed outside. Additionally, if a hole is made to run our wirings inside/outside, please use Silicone to cover up the additional space.

Before finalizing installation, please contact our technical support department at 631-670-1623 to have them verify the vehicle is visible in IntelliShift and is registering properly.